

Irt23R – Smart Rs485 RFID terminal with 2x16 characters LCD

Datasheet



Features

- Reads all EM4100 compatible 125kHz RFID cards;
- Up to 70mm reading range, depending on antenna and card;
- Serial communication channel (USART) 19200 bps, n, 8, 1 with easy to use binary protocol;
- Configurable RS-485 2-wires or RS-485 4-wires modes. Cascadable up to 32 devices;
- Convenient commands, some of them in transactional form, effectively performing group of operations
- Configurable encrypted serial communication;
- 1.5A over-current protected open-drain MOSFET output and over-voltage protected TTL input;
- 2 rows 16 characters dot-matrix LCD display and piezoelectric buzzer;
- RTC and 64kBytes data memory for card read event recording;
- Remotely updateable firmware;
- Field proven design;
- DC 12V, $\pm 20\%$ supply voltage; 50 mA ... 150 mA current consumption, depending on the antenna;
- 104 x 72 x 30 mm;
- Full functionality at -25 °C ... +75 °C environment temperatures;

Applications

- Access Control Systems
- Cashless Payment Systems
- Time and Attendance Systems
- Data Collection / Storage / Processing System

General Description

The **Irt23R** RS-485 RFID Reader reads all EM4100 compatible 125kHz RFID cards. It is an ideal choice for your system applications with RFID Cards, because of its affordable price, small size, rich command set, and its support of standard binary communication protocol. Software development kit (SDK), including all necessary datasheets, application notes, example applications with full source codes, software drivers and dll, helps developers to easily integrate **Irt23R** to the system.

Block Diagram

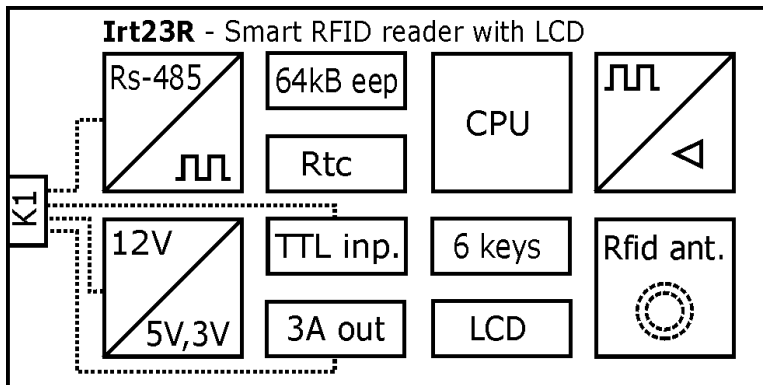

Cable description

K1 – Interface Cable			
No	Wire Color	Signal	Description
1	White (or gray)	Vcc	Supply voltage + (+10V ... 16V)
2	Brown	Gnd	Supply voltage - (0V, ground)
3	Yellow	Tx-	In Rs-485 4-wires mode – tx- ; in Rs-485 2-wires mode – not used
4	Green	Tx+	In Rs-485 4-wires mode – tx+ ; in Rs-485 2-wires mode – not used
5	Red	Rx-	In Rs-485 4-wires mode – rx- ; in Rs-485 2-wires mode – B
6	Black	Rx+	In Rs-485 4-wires mode – rx+ ; in Rs-485 2-wires mode – A
7	Orange	Inp	TTL input (internally pulled up to +5V)
8	Blue	Out	MOSFET transistor output (drain)

Technical specifications

Communication specifications	
Communication	Serial RS-485 (selectable - 2 or 4 wires): 19200 bps, n, 8, 1
Comm. Protocol	Binary multi-drop, XOR CRC checked frames
Comm. Encryption	On request. (32 bit, challenge-response)
CPU	8 bit MCU with 16kBytes flash memory, 9 MIPS throughput
Memory	64kBytes EEPROM and 16kBytes flash memories
LCD	2 rows by 16 characters dot-matrix
Software Updates	With programmer or through reader's own serial port
Reader specifications	
Operating frequency	125 kHz
Supported Tags (Cards)	EM4100, EM4102
Reading Distance	Up to 70 mm, depending on card (or tag)
Electrical specifications	
Supply voltage	DC +10V ... +16V
Current consumption	Max. 100 mA / 16V
Max. output voltage	DC +40V
Max. output current	DC 1.5 A
Input Voltage levels	TTL compatible voltage levels (-0.5V ... 6.5V)
Rs-485 voltage levels	-9V...+9V (all Rs485 wires are ESD protected with TVS-transient voltage suppressors)
Mechanical and environmental specifications	
Dimensions	104 x 72 x 30 mm
Weight	0.3 kg
Temperature Range	-20 °C ÷ +80 °C

Typical 4 wire Rs-485 bus connection diagram

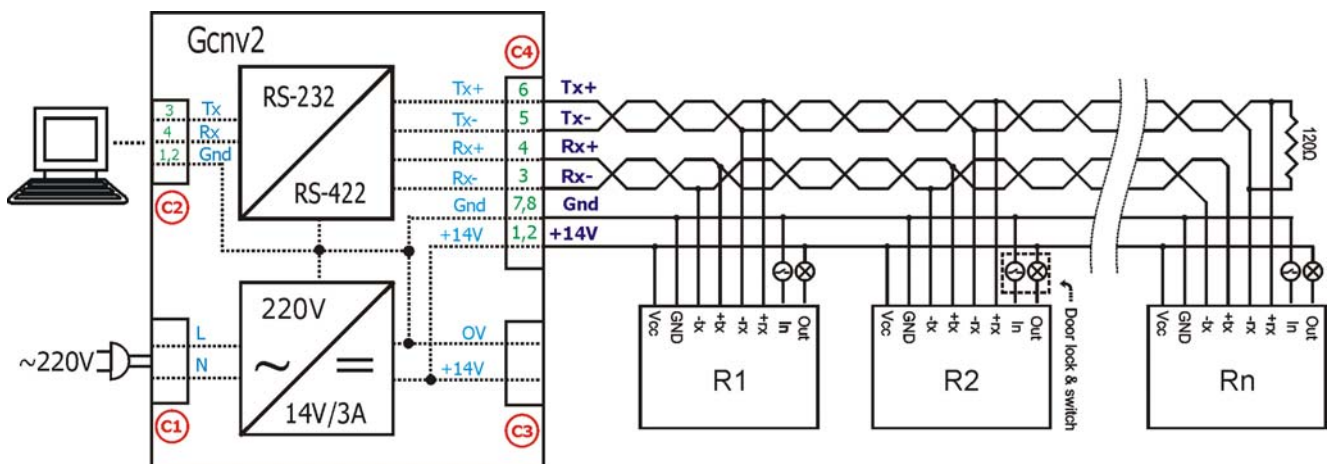

Mechanical drawings

